

OPERATOR'S MANUAL

PD20X-X

INCLUDING: OPERATION, INSTALLATION & MAINTENANCE

RELEASED: 6-11-96

REVISED: 5-6-10

(REV. R)

2" DIAPHRAGM PUMP 1:1 RATIO (METALLIC)



**READ THIS MANUAL CAREFULLY BEFORE INSTALLING,
OPERATING OR SERVICING THIS EQUIPMENT.**

It is the responsibility of the employer to place this information in the hands of the operator. Keep for future reference.

SERVICE KITS

Refer to Model Description Chart to match the pump material options.
67089-X major air valve assembly (see page 7).
637302 for air section repair (see page 6).
637309-XX for fluid section repair (see page 4). NOTE: This kit also contains several air motor seals which will need to be replaced.

PUMP DATA

Models	see Model Description Chart for "-XXX".
Pump Type	Metallic Air Operated Double Diaphragm
Material	see Model Description Chart.
Weight .. PD20A-XAX-XXX	64 lbs (29 kgs)
PD20A-XCX-XXX	133 lbs (60 kgs)
PD20A-AHX-XXX, -BHX-	122 lbs (55.3 kgs)
PD20A-ASX-XXX, -BSX-	122 lbs (55.3 kgs)
PD20A-FHX-XXX, -FSX-	114 lbs (51.7 kgs)
	(add 34 lbs [15.4 kgs] for Stainless steel air motor section)

Maximum Air Inlet Pressure

Ball check models	120 p.s.i.g. (8.3 bar)
Cone check models	100 p.s.i.g. (6.9 bar)

Maximum Material Inlet Pressure

.....	10 p.s.i.g. (.69 bar)
-------	-----------------------

Maximum Outlet Pressure

Ball check models	120 p.s.i.g. (8.3 bar)
Cone check models	100 p.s.i.g. (6.9 bar)

Maximum Flow Rate (flooded inlet)

Ball check models	170 g.p.m. (644 l.p.m.)
Cone check models	130 g.p.m. (492 l.p.m.)

Displacement / Cycle @ 100 p.s.i.g.

.....	1.4 gal. (5.3 lit.)
-------	---------------------

Maximum Particle Size

Ball check models	1/4" dia. (6.4 mm)
Cone check models	1/2" dia. (12.7 mm)

Maximum Temperature Limits (diaphragm / ball / seal material)

E.P.R. / EPDM	-60° to 280° F (-51° to 138° C)
Hytre [®]	-20° to 150° F (-29° to 66° C)
Neoprene	0° to 200° F (-18° to 93° C)
Nitrile	10° to 180° F (-12° to 82° C)
PVDF (Kynar [®])	10° to 200° F (-12° to 93° C)
Santoprene [®]	-40° to 225° F (-40° to 107° C)
PTFE	40° to 225° F (4° to 107° C)
Viton [®]	-40° to 350° F (-40° to 177° C)

Dimensional Data

see page 8

Mounting Dimension

9-1/16" x 10-1/16" (230 mm x 256 mm)

Noise Level @ 70 p.s.i., 60 c.p.m.^①

85.0 db(A)^②

① Tested with 67263 muffler assembly installed.
② The pump sound pressure levels published here have been updated to an Equivalent Continuous Sound Level (L_{Aeq}) to meet the intent of ANSI S1.13-1971, CAGI-PNEU-ROP S5.1 using four microphone locations.

NOTICE: All possible options are shown in the chart, however, certain combinations may not be recommended, consult a representative or the factory if you have questions concerning availability.

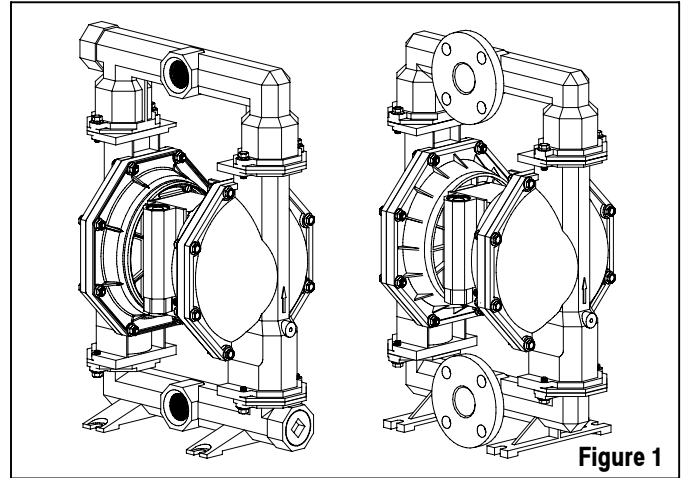

Figure 1

MODEL DESCRIPTION CHART

PD20 X - X X X - X X X - A (03)	
AIR MOTOR / AIR CAP MATERIAL	
A - Aluminum / Aluminum	
C - Stainless Steel / Cast Iron	
S - Stainless Steel / Stainless Steel	
THREAD	
A - N.P.T.F.	B - BSP
F - 2" A.N.S.I. / DIN Flange	
FLUID CAPS & MANIFOLD MATERIAL	
A - Aluminum	H - Hastelloy - C
C - Cast Iron	S - Stainless Steel
HARDWARE MATERIAL	
P - Plated Steel	S - Stainless Steel
SEAT MATERIAL	
A - Santoprene	H - Hard 440 Stainless Steel
C - Hytre	K - PVDF (Kynar)
E - Carbon Steel	L - Hastelloy - C
F - Aluminum	S - 316 Stainless Steel
G - Nitrile	O - (Cone Check)
BALL MATERIAL	(□) Cone Check models
A - Santoprene	L - Viton (□)
C - Hytre	N - Neoprene (□)
G - Nitrile	S - 316 Stainless Steel
J - Nitrile (□)	T - PTFE
K - E.P.R. (□)	V - Viton
DIAPHRAGM MATERIAL	
A - Santoprene	M - Medical Grade Santoprene
C - Hytre	T - PTFE / Santoprene
G - Nitrile	V - Viton
CONE CHECK FLOW	
03 - Bottom Discharge	
FLUID SECTION SERVICE KIT SELECTION	PD20X - XXX - X X X
EXAMPLE: MODEL # PD20A-ACS-SAA	637309 - <input checked="" type="checkbox"/> <input checked="" type="checkbox"/>
FLUID SECTION SERVICE KIT # 637309-AA	Ball <input type="checkbox"/> Diaphragm <input type="checkbox"/>

INGERSOLL RAND COMPANY

209 NORTH MAIN STREET □ BRYAN, OHIO 43506

☎ (800) 276-4658 • FAX (800) 266-7016

©2010

CCN 99594046

www.ingersollrandproducts.com

ARO

IR Ingersoll Ran
Industrial Technologies

OPERATING AND SAFETY PRECAUTIONS

READ, UNDERSTAND, AND FOLLOW THIS INFORMATION TO AVOID INJURY AND PROPERTY DAMAGE.



⚠ WARNING EXCESSIVE AIR PRESSURE. Can cause personal injury, pump damage or property damage.

- Do not exceed the maximum inlet air pressure as stated on the pump model plate.
- Be sure material hoses and other components are able to withstand fluid pressures developed by this pump. Check all hoses for damage or wear. Be certain dispensing device is clean and in proper working condition.

⚠ WARNING STATIC SPARK. Can cause explosion resulting in severe injury or death. Ground pump and pumping system.

- Use the pump grounding screw terminal provided. Use ARO part no. 66885-1 ground kit or connect a suitable ground wire (12 ga. min.) to a good earth ground source.
- Secure pump, connections and all contact points to avoid vibration and generation of contact or static spark.
- Consult local building codes and electrical codes for specific grounding requirements.
- After grounding, periodically verify continuity of electrical path to ground. Test with an ohmmeter from each component (e.g., hoses, pump, clamps, container, spray gun, etc.) to ground to insure continuity. Ohmmeter should show 0.1 ohms or less.
- Submerge the outlet hose end, dispensing valve or device in the material being dispensed if possible. (Avoid free streaming of material being dispensed.)
- Use hoses incorporating a static wire.
- Use proper ventilation.
- Keep inflammables away from heat, open flames and sparks.
- Keep containers closed when not in use.

⚠ WARNING Pump exhaust may contain contaminants. Can cause severe injury. Pipe exhaust away from work area and personnel.

- In the event of a diaphragm rupture, material can be forced out of the air exhaust muffler.
- Pipe the exhaust to a safe remote location when pumping hazardous or inflammable materials.
- Use a grounded 1" minimum i.d. hose between the pump and the muffler.

⚠ WARNING HAZARDOUS PRESSURE. Can result in serious injury or property damage. Do not service or clean pump, hoses or dispensing valve while the system is pressurized.

- Disconnect air supply line and relieve pressure from the system by opening dispensing valve or device and / or carefully and slowly loosening and removing outlet hose or piping from pump.

⚠ WARNING HAZARDOUS MATERIALS. Can cause serious injury or property damage. Do not attempt to return a pump to the factory or service center that contains hazardous material. Safe handling practices must comply with local and national laws and safety code requirements.

- Obtain Material Safety Data Sheets on all materials from the

supplier for proper handling instructions.

⚠ WARNING EXPLOSION HAZARD. Models containing aluminum wetted parts cannot be used with III.-Trichloroethane, Methylene Chloride or other Halogenated Hydrocarbon solvents which may react and explode.

- Check pump motor section, fluid caps, manifolds and all wetted parts to assure compatibility before using with solvents of this type.

⚠ WARNING MISAPPLICATION HAZARD. Do not use models containing aluminum wetted parts with food products for human consumption. Plated parts can contain trace amounts of lead.

⚠ CAUTION Verify the chemical compatibility of the pump wetted parts and the substance being pumped, flushed or recirculated. Chemical compatibility may change with temperature and concentration of the chemical(s) within the substances being pumped, flushed or circulated. For specific fluid compatibility, consult the chemical manufacturer.

⚠ CAUTION Maximum temperatures are based on mechanical stress only. Certain chemicals will significantly reduce maximum safe operating temperature. Consult the chemical manufacturer for chemical compatibility and temperature limits. Refer to PUMP DATA on page 1 of this manual.

⚠ CAUTION Be certain all operators of this equipment have been trained for safe working practices, understand it's limitations, and wear safety goggles / equipment when required.

⚠ CAUTION Do not use the pump for the structural support of the piping system. Be certain the system components are properly supported to prevent stress on the pump parts.

- Suction and discharge connections should be flexible connections (such as hose), not rigid piped, and should be compatible with the substance being pumped.

⚠ CAUTION Prevent unnecessary damage to the pump. Do not allow pump to operate when out of material for long periods of time.

- Disconnect air line from pump when system sits idle for long periods of time.

⚠ CAUTION Use only genuine ARO replacement parts to assure compatible pressure rating and longest service life.

NOTICE Replacement warning labels are available upon request: "Static Spark & Diaphragm Rupture" pn \ 94080.

⚠ WARNING = Hazards or unsafe practices which could result in severe personal injury, death or substantial property damage.

⚠ CAUTION = Hazards or unsafe practices which could result in minor personal injury, product or property damage.

NOTICE = Important installation, operation or maintenance information.

GENERAL DESCRIPTION

The ARO diaphragm pump offers high volume delivery even at low air pressure and a broad range of material compatibility options available. Refer to the model and option chart. ARO pumps feature stall resistant design, modular air motor / fluid sections.

Air operated double diaphragm pumps utilize a pressure differential in the air chambers to alternately create suction and positive fluid pressure in the fluid chambers, valve checks insure a positive flow of fluid.

Pump cycling will begin as air pressure is applied and it will continue to pump and keep up with the demand. It will build and maintain line pressure and will stop cycling once maximum line pressure is reached (dispensing device closed) and will resume pumping as needed.

AIR AND LUBE REQUIREMENTS

⚠ WARNING EXCESSIVE AIR PRESSURE. Can cause pump damage, personal injury or property damage.

- A filter capable of filtering out particles larger than 50 microns should be used on the air supply. There is no lubrication required other than the “O” ring lubricant which is applied during assembly or repair.
- If lubricated air is present, make sure that it is compatible with the Nitrile “O” rings in the air motor section of the pump.

OPERATING INSTRUCTIONS

- Always flush the pump with a solvent compatible with the material being pumped if the material being pumped is subject to “setting up” when not in use for a period of time.
- Disconnect the air supply from the pump if it is to be inactive for a few hours.
- The outlet material volume is governed not only by the air supply but also by the material supply available at the inlet. The material supply tubing should not be too small or restrictive. Be sure not to use hose which might collapse.
- When the diaphragm pump is used in a forced-feed (flooded inlet) situation it is recommended that a “Check Valve” be installed at the air inlet.
- Secure the diaphragm pump legs to a suitable surface to insure against damage by vibration.

PARTS AND SERVICE KITS

Refer to the part views and descriptions as provided on page 4 through 7 for parts identification and Service Kit information.

- Certain ARO “Smart Parts” are indicated which should be available for fast repair and reduction of down time.
- Service kits are divided to service two separate diaphragm pump functions: 1. AIR SECTION, 2. FLUID SECTION. The FLUID SECTION is divided further to match typical part MATERIAL OPTIONS.

MAINTENANCE

- Provide a clean work surface to protect sensitive internal moving parts from contamination from dirt and foreign matter during service disassembly and reassembly.
- Keep good records of service activity and include pump in preventive maintenance program.
- Before disassembling, empty captured material in the outlet manifold by turning the pump upside down to drain material from the pump.

FLUID SECTION DISASSEMBLY

1. Remove (61) outlet manifold, (60) inlet manifold.
2. Remove (22) balls, (19) “O” rings (if applicable) and (21) seats.
3. Remove (15) fluid caps.
NOTE: Only PTFE diaphragm models use a primary diaphragm (7) and a backup diaphragm (8). Refer to the auxiliary view in the Fluid Section illustration.
4. Remove the (6) diaphragm washer, (7) or (7/8) diaphragms, and (5) backup washer.
NOTE: Do not scratch or mar the surface of (1) diaphragm rod.

FLUID SECTION REASSEMBLY

- Reassemble in reverse order. Refer to the torque requirements on page 5.
- Clean and inspect all parts. Replace worn or damaged parts with new parts as required.
- Lubricate (1) diaphragm rod and (144) “U” cup with Lubriplate® FML-2 grease (94276 grease packet is included in service kit).
- For models with PTFE diaphragms: Item (8) Santoprene diaphragm is installed with the side marked “AIR SIDE” towards the pump center body. Install the PTFE diaphragm (7) with the side marked “FLUID SIDE” towards the (15) fluid cap.
- Re-check torque settings after pump has been re-started and run a while.

PARTS LIST / PD20X-X-X FLUID SECTION

FLUID SECTION SERVICE KITS (637309-XX)

★ KITS INCLUDE: BALLS / CONE CHECKS (see Ball or Cone Check Option, refer to -XX in chart below), DIAPHRAGMS (see Diaphragm Option, refer to -XX in chart below), and items 19, 70, 144, 175, (listed below) plus 174 and 94276 Lubriplate FML-2 grease (page 6).

SEAT OPTIONS PD20X-XXX-XXX					CONE CHECK OPTIONS PD20X-XXX-0XX				
★ "21"					★ "41"				
-XXX	Seat	Qty	[Mtl]		-XXX	Seat	Qty	[Mtl]	
-AXX	94328-A	(4)	[SP]		-HXX	94354	(4)	[SH]	
-CXX	94328-C	(4)	[H]		-KXX	94477-K	(4)	[K]	
-EXX	95677	(4)	[C]		-LXX	95639	(4)	[Ha]	
-FXX	95673	(4)	[A]		-SXX	94353	(4)	[SS]	
-GXX	94328-G	(4)	[B]						

NOTE: Seat options -AXX, -CXX and -GXX and cone check options -0XX do not require item 19 "O" ring.

BALL OPTIONS PD20X-XXX-XXX				DIAPHRAGM OPTIONS PD20X-XXX-XXX										
★ "22" (2-1/2" dia.)				★ SERVICE KIT		★ "7"			★ "8"			★ "19"		
-XXX	Ball	Qty	[Mtl]	-XXX	-XX = (Ball) -XX = (Diaphragm)	Diaphragm	Qty	[Mtl]	Diaphragm	Qty	[Mtl]	"O" Ring	Qty	[Mtl]
-XAX	93358-A	(4)	[SP]	-XXA	637309-XA	94329-A	(2)	[SP]	-----	---	---	94356	(4)	[E]
-XCX	93358-C	(4)	[H]	-XXC	637309-XC	94329-C	(2)	[H]	-----	---	---	Y327-237	(4)	[V]
-XGX	93358-2	(4)	[B]	-XXG	637309-XG	94329-G	(2)	[B]	-----	---	---	Y325-237	(4)	[B]
-XSX	94805	(4)	[SS]	-XXM	637309-XM	94329-M	(2)	[MSP]	-----	---	---	Y328-237	(4)	[T]
-XTX	93358-4	(4)	[T]	-XXT	637309-XT	94355-T	(2)	[T]	94330-A	(2)	[SP]	Y328-237	(4)	[T]
-XVX	93358-3	(4)	[V]	-XXV	637309-XV	95344	(2)	[V]	-----	---	---	Y327-237	(4)	[V]

CENTER SECTION PART OPTIONS PD20X-XXX-XXX								
Item	Description (size)	Qty	PD20A-XXX-XXX		PD20C-XXX-XXX		PD20S-XXX-XXX	
			Part No.	[Mtl]	Part No.	[Mtl]	Part No.	[Mtl]
5	Backup Washer	(2)	94357-1	[A]	94357-2	[SS]	94357-2	[SS]
68	Air Cap	(1)	94324-1	[A]	94345-1	[CI]	94349-1	[SS]
69	Air Cap	(1)	94324-2	[A]	94345-2	[CI]	94349-2	[SS]
126	Pipe Plug (1/4 - 18 N.P.T. x 7/16")	(2)	-----	---	Y17-51-S	[SS]	Y17-51-S	[SS]
★ ✓ 175	"O" Ring (3/32" x 1" o.d.)	(2)	Y325-117	[B]	-----	---	-----	---
★ ✓	(3/32" x 1-1/16" o.d.)	(2)	-----	---	Y325-118	[B]	Y325-118	[B]
181	Roll Pin (5/32" o.d. x 3/4" long)	(4)	-----	---	Y178-56-S	[SS]	Y178-56-S	[SS]

MANIFOLD THREAD / FLUID CAP MATERIAL OPTIONS PD20X-XXX-XXX												
Item	Description (size)	Qty	PD20X-XAX-XXX	PD20X-XCX-XXX	PD20X-XHX-XXX	PD20X-FHX-XXX	PD20X-XSX-XXX	PD20X-FSX-XXX				
6	Diaphragm Washer	(2)	94357-1 [A]	94357-2 [SS]	94357-3 [Ha]	94357-3 [Ha]	94357-2 [SS]	94357-2 [SS]				
9	Washer	(2)	93065 [SS]	93065 [SS]	95683 [Ha]	95683 [Ha]	93065 [SS]	93065 [SS]				
14	Screw (5/8" - 18 x 2-1/2")	(2)	Y5-111-T [SS]	Y5-111-T [SS]	95682 [Ha]	95682 [Ha]	Y5-111-T [SS]	Y5-111-T [SS]				
15	Fluid Cap	(2)	94325 [A]	94346 [CI]	95679 [Ha]	95679 [Ha]	95570 [SS]	95570 [SS]				
60	Inlet Manifold	(1)	94327-[☆] [A]	94347-[☆] [CI]	95680-[☆] [Ha]	96341 ⚡ [Ha]	95510-[☆] [SS]	95512 ⚡ [SS]				
61	Outlet Manifold	(1)	94326-[☆] [A]	94348-[☆] [CI]	95681-[☆] [Ha]	96342 ⚡ [Ha]	95511-[☆] [SS]	95513 ⚡ [SS]				
63	Pipe Plug 2 - 11-1/2 N.P.T.	(2)	Y17-128 [A]	Y17-28-C [C]	-----	---	-----	---				
	R-2, 2 - 11 BSP	(2)	94439-2 [A]	94439-1 [C]	-----	---	-----	---				

★ For N.P.T.F. thread models (PD20X-AXX-XXX), use "-1", For BSP thread models (PD20X-BXX-XXX), use "-2"

⚡ Flange models

EXTERNAL HARDWARE OPTION PD20X-XXX-XXX						PD20X-XXX-0XX and -0XX-A03 only					
Item	Description (size)	Qty	Part No.	[Mtl]	Part No.	[Mtl]	Item	Description (size)	Qty	Part No.	[Mtl]
26	Screw (M10 x 1.5 - 6g x 35 mm)	(8)	94409-1	[C]	94409-2	[SS]	76	Washer (2.295" i.d. x 3.375" o.d.)	(4)	95697	[SS]
27	Screw (M10 x 1.5 - 6g x 45 mm)	(16)	94990-1	[C]	94990	[SS]	77	Washer (1.875" i.d. x 3.375" o.d.)	(4)	95696	[SS]
29	Nut (M10 x 1.5 - 6g)	(16)	94992-1	[C]	94992	[SS]					

COMMON PARTS									
Item	Description (size)	Qty	Part No.	[Mtl]	Item	Description (size)	Qty	Part No.	[Mtl]
1	Rod	(1)	94358	[C]	131	Screw (M10 x 1.5 - 6g x 120 mm)	(4)	94531	[C]
43	Ground Lug (see page 7)	(1)	93004	[Co]	★ ✓ 144	"U" Cup (3/16" x 1-3/8" o.d.)	(2)	Y186-51	[B]
★ ✓ 70	Gasket	(2)	94100	[B]	✓ 180	Washer (0.406" i.d. x 0.031" thick)	(4)	94098	[Co]

□ "Smart Parts", keep these items on hand in addition to the service kits for fast repair and reduction of down time.

✓ Air Motor Kit Parts, see page 6.

PARTS LIST / PD20X-X-X FLUID SECTION

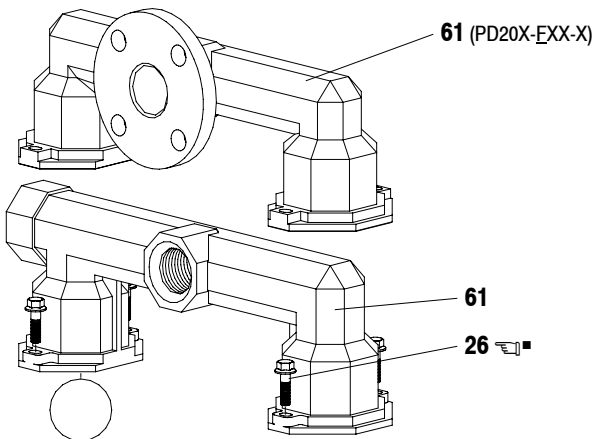

MATERIAL CODE	
[A]	= Aluminum
[B]	= Nitrile
[C]	= Carbon Steel
[Co]	= Copper
[CI]	= Cast Iron
[E]	= E.P.R.
[H]	= Hytrel
[Ha]	= Hastelloy-C
[K]	= PVDF (Kynar)
[MSP]	= Medical Grade Santoprene
[N]	= Neoprene
[SH]	= Hard Stainless Steel
[SP]	= Santoprene
[SS]	= Stainless Steel
[T]	= PTFE
[V]	= Viton

COLOR CODE		
Material	Diaphragm Color	Ball / Cone Color
E.P.R.	N / A	Blue (+)
Hytrel	Cream	Cream
Neoprene	N / A	Green (+)
Nitrile	Black	Red (+)
Santoprene	Tan	Tan
Santoprene (Backup)	Green	N / A
PTFE	White	White
Viton	Yellow (-)	Yellow (+)
	(-) Dash	(+) Dot

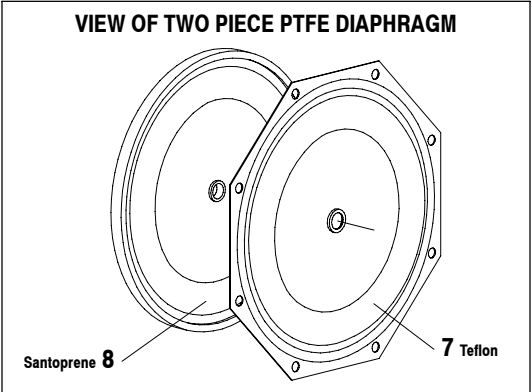
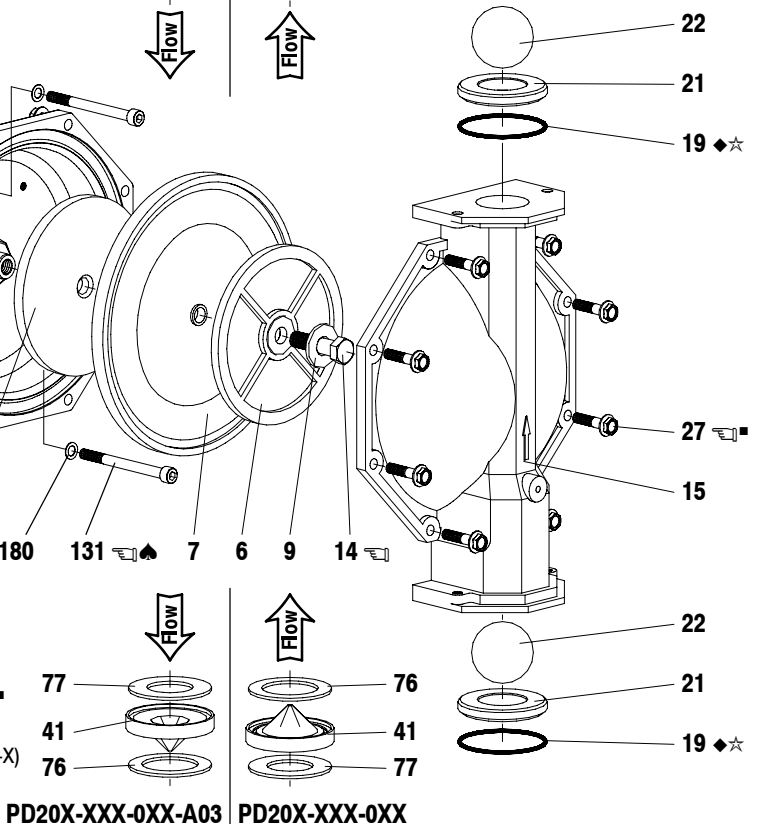
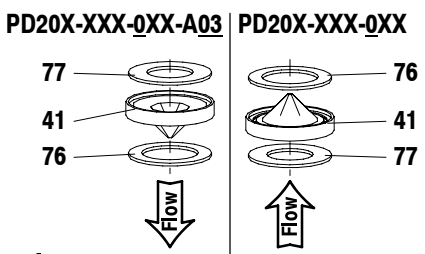
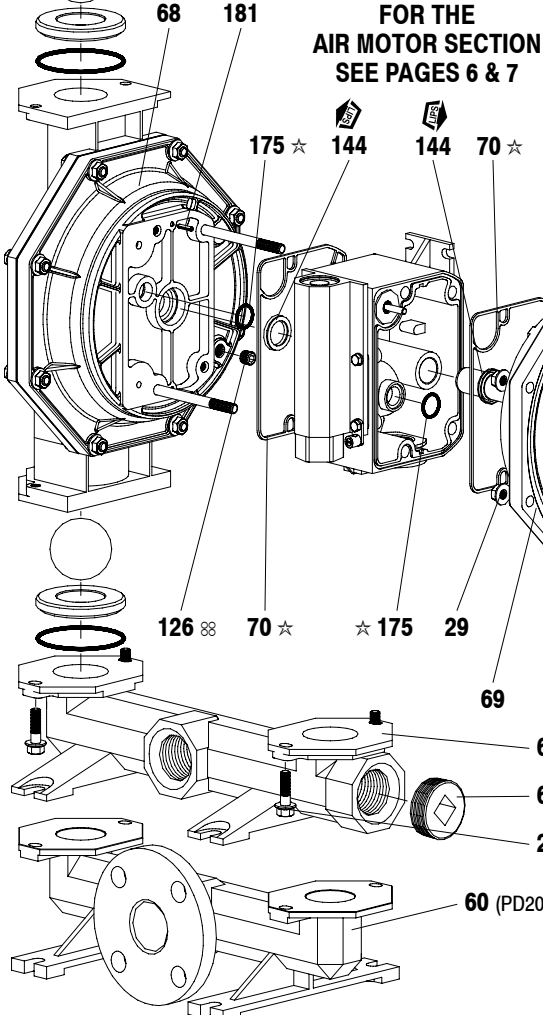
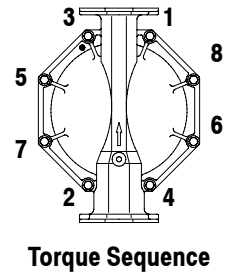

TORQUE REQUIREMENTS

NOTE: DO NOT OVERTIGHTEN FASTENERS.

ALL FASTENERS ARE METRIC.

(14) Diaphragm screw, apply Loctite #271 to threads, 65 - 70 ft lbs (88.1 - 94.9 Nm).

(26 and 27) Fluid cap / manifold screw 30 - 40 ft lbs (40.7 - 54.2 Nm).

(131) Screw 35 - 40 ft lbs (47.5 - 54.2 Nm).

- Apply anti-seize compound to threads when using stainless steel fasteners and stainless steel wet ends.

LUBRICATION / SEALANTS

- Apply Lubriplate FML-2 grease to all "O" rings, "U" cups & mating parts.
- Apply Loctite 242 to threads at assembly.
- Apply PTFE tape to threads.

Figure 2

- Not used with PD20X-XXX-AXX, -CXX, -GXX & -0XX.
- Lubriplate FML-2 is a white food grade petroleum grease.

PARTS LIST / PD20X-X-X AIR SECTION

✓ Indicates parts included in 637302 Air Section Service Kit shown below and items (70), (144), (175), (180) shown on page 4.

AIR MOTOR PARTS

Item	Description (size)	Qty	Part No.	[Mtl]
101	Center Body (PD20A-X-X)	(1)	94028	[A]
	(PD20C-X-X, PD20S-X-X)	(1)	94109	[SS]
103	Bushing	(1)	94092	[D]
107	Inlet Plug	(1)	94034	[C]
109	Piston	(1)	92011	[D]
✓ 110	“U” Cup (3/16” x 1-3/8” o.d.)	(1)	Y186-51	[B]
111	Spool (PD20A-X-X)	(1)	92005	[A]
	(PD20C-X-X, PD20S-X-X)	(1)	93047	[C]
112	Washer (1.556” o.d.)	(5)	92877	[Z]
✓ 113	“O” Ring (small) (1/8” x 1-1/4” o.d.)	(5)	Y325-214	[B]
✓ 114	“O” Ring (large) (3/32” x 1-9/16” o.d.)	(7)	Y325-126	[B]
□ 115	Spacer	(4)	92876	[Z]
116	Spacer	(1)	94027	[A]
118	Actuator Pin (0.250” x 2.276” long)	(2)	94083	[SS]
121	Sleeve	(2)	94084	[D]
○ 127	90° St. Elbow (1-1/2 - 11-1/2 N.P.T.)	(1)	94860	[C/I]
✓ 132	Gasket (valve body)	(1)	94099	[B]
133	Lockwasher (1/4”) (PD20A-X-X)	(3)	Y117-416-C	[C]
	(PD20C-X-X, PD20S-X-X)	(3)	Y14-416-T	[SS]
134	Screw (M6 x 1.0 x 16 mm) (PD20A-X-X)	(4)	96721030	[C]
	(PD20C-X-X, PD20S-X-X)	(4)	96720081	[SS]
135	Valve Block (PD20A-X-X)	(1)	94032	[A]
	(PD20C-X-X, PD20S-X-X)	(1)	94318	[SS]
136	Piston Plug	(1)	94033	[D]
✓ 146	“O” Ring ◆ (3/32” x 1-1/16” o.d.)	(1)	Y325-118	[B]

Item	Description (size)	Qty	Part No.	[Mtl]
✓ 147	“O” Ring ◆ (1/8” x 1/2” o.d.)	(2)	Y325-202	[B]
✓ 166	Track Gasket ●	(1)	94026	[B]
✓ 167	Pilot Piston (includes 168 and 169)	(1)	67164	[D]
168	“O” Ring (3/32” x 5/8” o.d.)	(2)	94433	[U]
169	“U” Cup (1/8” x 7/8” o.d.)	(1)	Y240-9	[B]
170	Piston Sleeve	(1)	94081	[Br]
✓ 171	“O” Ring (3/32” x 1-1/8” o.d.)	(1)	Y325-119	[B]
✓ 172	“O” Ring (1/16” x 1-1/8” o.d.)	(1)	Y325-22	[B]
✓ 173	“O” Ring (1/16” x 1-3/8” o.d.)	(2)	Y325-26	[B]
*✓ 174	“O” Ring (1/8” x 1/2” o.d.)	(2)	Y325-202	[B]
✓ 176	Diaphragm (check valve)	(2)	94102	[SP]
✓ 177	Retaining Ring (PD20X-XXP-XXX)	(1)	Y147-16-C	[C]
	(PD20X-XXS-XXX)	(1)	Y147-16-S	[SS]
○ 201	Muffler	(1)	94810	
★ ✓	Lubriplate FML-2 Grease	(1)	94276	
	Lubriplate Grease Packets (10)		637308	
◆ Used on models PD20C-XXX-XXX and PD20S-XXX-XXX only.				
● Used on models PD20A-XXX-XXX only.				
○ Items not shown				

MATERIAL CODE

[A] = Aluminum	[D] = Acetal	[SS] = Stainless Steel
[B] = Nitrile	[I] = Iron	[U] = Polyurethane
[Br] = Brass	[SP] = Santoprene	[Z] = Zinc
[C] = Carbon Steel		

AIR MOTOR SECTION SERVICE

Service is divided into two parts - 1. Pilot Valve, 2. Major Valve.

GENERAL REASSEMBLY NOTES:

- Air Motor Section Service is continued from Fluid Section repair.
- Inspect and replace old parts with new parts as necessary. Look for deep scratches on metallic surfaces, and nicks or cuts in “O” rings.
- Take precautions to prevent cutting “O” rings upon installation.
- Lubricate “O” rings with Lubriplate FML-2 grease.
- Do not over-tighten fasteners, refer to torque specification block on view.
- Re-torque fasteners following restart.
- SERVICE TOOLS - To aid in the installation of (168) “O” rings onto the (167) pilot piston, use tool # 204130-T, available from ARO.

PILOT VALVE DISASSEMBLY

1. A light tap on (118) should expose the opposite (121) sleeve, (167) pilot piston and other parts.
2. Remove (170) sleeve, inspect inner bore of sleeve for damage.

PILOT VALVE REASSEMBLY

1. Clean and lubricate parts not being replaced from service kit.

2. Install new (171 and 172) “O” rings, replace (170) sleeve.
3. Install new (168) “O” rings and (169) seal - Note the lip direction. Lubricate and replace (167).
4. Reassemble remaining parts, replace (173 and 174) “O” rings.

MAJOR VALVE DISASSEMBLY

1. Remove (135) valve block, exposing gaskets (166 and 132) and (176) checks.
2. Remove (177) snap ring and (107) inlet plug.
3. On the side opposite the air inlet, push on the inner diameter of (111) spool. This will force the (136) piston plug and (109) piston out. Continue pushing the (111) spool and remove. Check for scratches or gouges.
4. Remove the Major Valve parts (112 - 116).

MAJOR VALVE REASSEMBLY

1. Replace (112) washer, (114) “O” ring and (113) “O” ring onto (115) spacer and insert etc. Continue this routine to build the major valve stack.

NOTE: Be careful to orient spacer legs away from blocking internal ports.

2. Replace (111) spool on (136) plug, (110) seal on (109) piston and replace (109), (136) plug and (177) snap ring.

PARTS LIST / PD20X-X-X AIR SECTION

MAJOR VALVE CROSS SECTION DETAIL

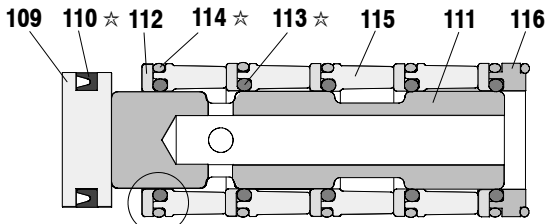
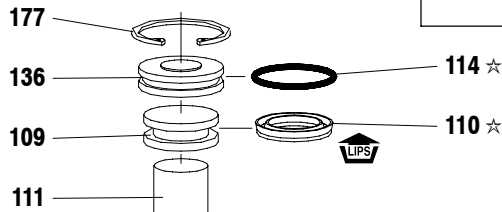
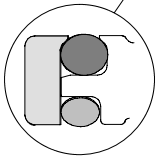
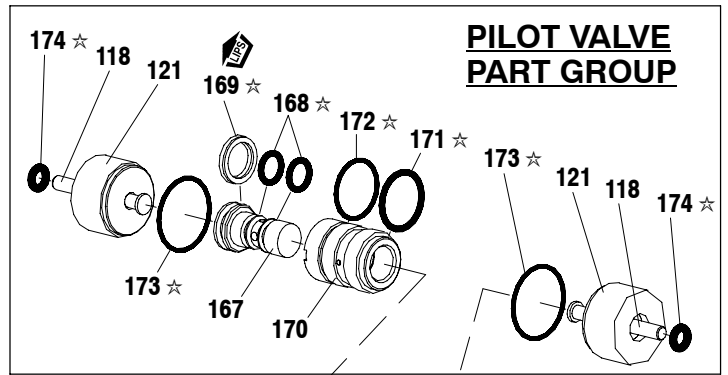

Figure 4

PILOT VALVE PART GROUP



◆ Substitute these "O" rings for "166" on models PD20S-X-X & PD20C-X-X.

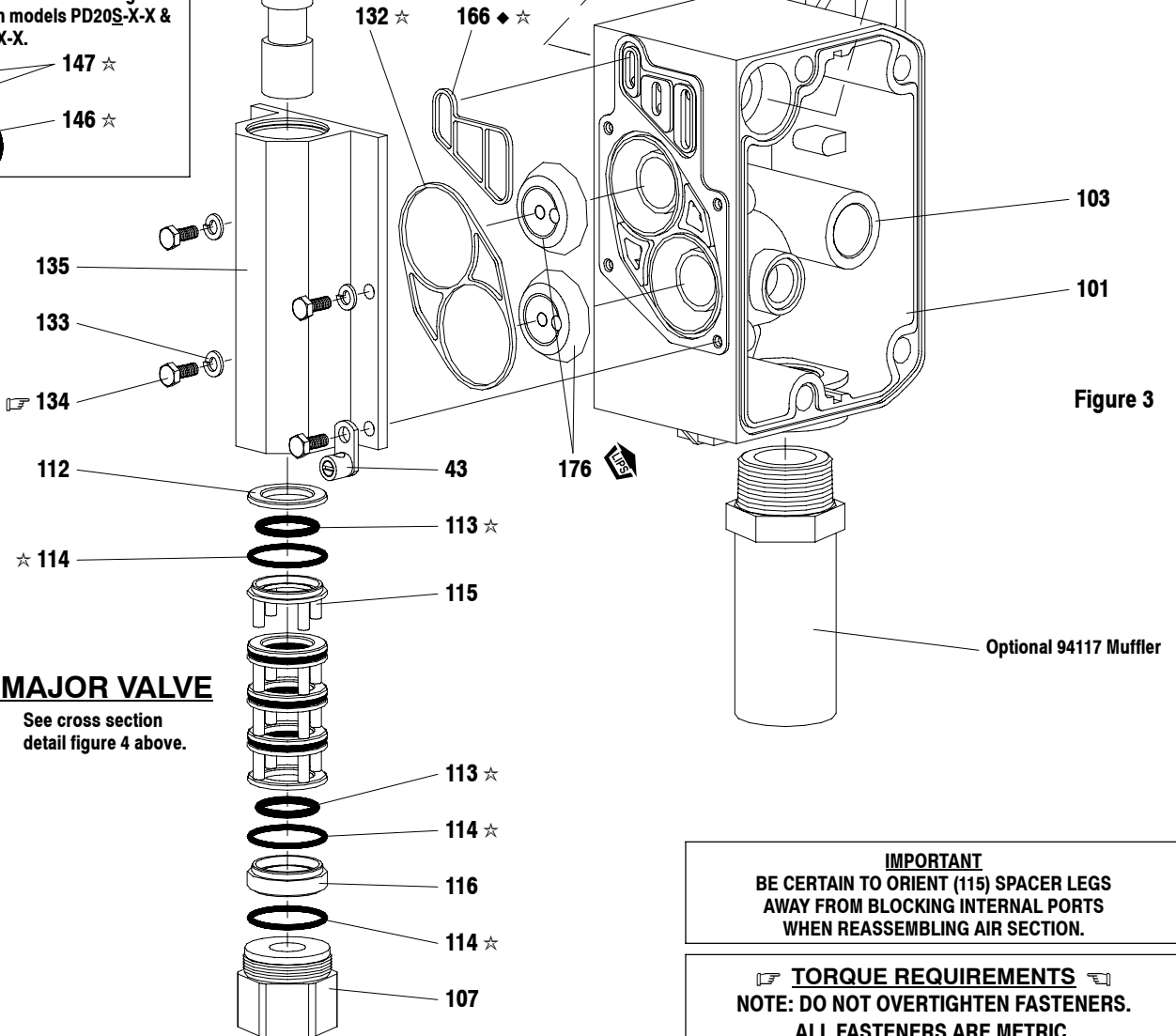
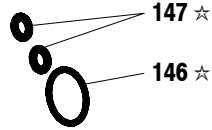

Figure 3

MAJOR VALVE

See cross section detail figure 4 above.

IMPORTANT
BE CERTAIN TO ORIENT (115) SPACER LEGS AWAY FROM BLOCKING INTERNAL PORTS WHEN REASSEMBLING AIR SECTION.

TORQUE REQUIREMENTS
NOTE: DO NOT OVERTIGHTEN FASTENERS.
ALL FASTENERS ARE METRIC.
Torque (134) screw to 40 - 50 in. lbs (4.5 - 5.6 Nm).

LUBRICATION / SEALANTS
☆ Apply Lubriplate FML-2 grease to "O" rings, "U" Cups & mating parts.

Valve Assembly	Pump Models	Items Included
67089-1	PD20A-	107 - 116, 132, 135, 136, 166, 176, 177
67089-2	PD20C-, PD20S-	107 - 116, 132, 135, 136, 146, 147, 176, 177

TROUBLE SHOOTING

Product discharged from exhaust outlet.

- Check for diaphragm rupture.
- Check tightness of (14) diaphragm screw.

Air bubbles in product discharge.

- Check connections of suction plumbing.
- Check "O" rings between intake manifold and inlet side fluid caps.
- Check tightness of (14) diaphragm screw.

Motor blows air or stalls.

- Check (176) check valve for damage or wear.
- Check for restrictions in valve / exhaust.

Low output volume, erratic flow, or no flow.

- Check air supply.
- Check for plugged outlet hose.
- Check for kinked (restrictive) outlet material hose.
- Check for kinked (restrictive) or collapsed inlet material hose.
- Check for pump cavitation – suction pipe should be sized at least as large as the inlet thread diameter of the pump for proper flow if high viscosity fluids are being pumped. Suction hose must be a non-collapsing type, capable of pulling a high vacuum.
- Check all joints on the inlet manifolds and suction connections. These must be air tight.
- Inspect the pump for solid objects logged in the diaphragm chamber or the seat area.

DIMENSIONAL DATA

(Dimensions shown are for reference only, they are displayed in inches and millimeters (mm).)

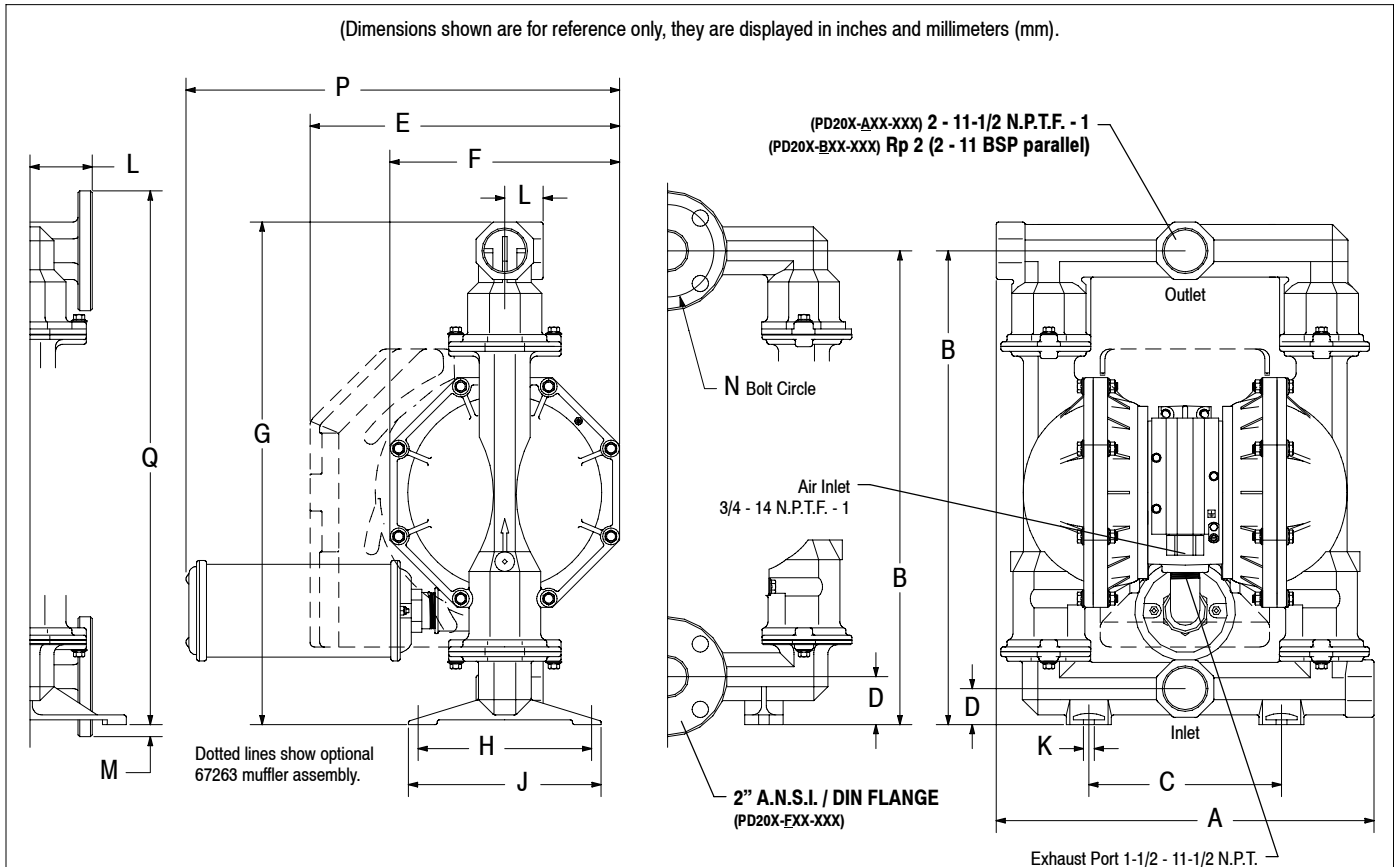

DIMENSIONS

A - see below	E - 16-3/16" (411.2 mm)	J - 10-1/16" (255.6 mm)	N - 4.834" (122.8 mm)
B - 24-3/4" (628.7 mm)	F - 12" (304.8 mm)	K - 9/16" (14.3 mm)	P - 21-5/8" (548 mm)
C - 10-1/16" (255.6 mm)	G - 26-1/4" (666.8 mm)	L - see below	Q - 27-7/8" (708.0 mm)
D - see below	H - 9-1/16" (230.2 mm)	M - 5/8" (15.9 mm)	

	"A"	"D"	"L"
PD20X-XAX-XXX	19-3/4" (501.4 mm)	1-7/8" (47.6 mm)	2" (50.8 mm)
PD20X-XCX-XXX	19-3/4" (501.4 mm)	1-7/8" (47.6 mm)	2" (50.8 mm)
PD20X-AHX-XXX, -BHX	19-1/4" (488.7 mm)	2-1/2" (63.5 mm)	2-3/32" (53.0 mm)
PD20X-ASX-XXX, -BSX	19-1/4" (488.7 mm)	2-1/2" (63.5 mm)	2-3/32" (53.0 mm)
PD20X-FHX-XXX, -FSX	19-1/4" (488.7 mm)	2-1/2" (63.5 mm)	3-1/4" (82.6 mm)

Figure 6